

WITTKE

Wittke Front Loaders



Wittke Front Loaders

ANYTHING IS POSSIBLE WITH A WITTKE™

With their robust yet streamlined design and constructed with AR450 Abrasion Resistant Steel for higher augmented payload capacity, the Wittke™ Front Loaders optimize waste capacity and revenue. With quick arm cycles, Wittke™ ensures efficient daily routes.

The Wittke™ Starlight is renowned for its agility, handling both residential and commercial routes. Its low body weight maximizes legal payload capacity, and its rapid-lifting cycle guarantees fast loading on the route.

The Wittke™ Superduty stands as the most rugged among front loaders, engineered for minimal maintenance requirements and to deliver the lowest total cost of ownership. This is achieved through the integration of upsized body structural members with time-tested Wittke™ designs.

Elevate your waste management strategy with Wittke™ Front Loaders!

Laying the foundations for a truly exceptional product.

WITTKE™ INNOVATIONS

With a strong emphasis on innovation, Wittke's engineering team has crafted a comprehensive range of customizable options to cater to even the most stringent customer requirements. We are poised and eager to embrace emerging industry trends and fulfill evolving customer demands. This perpetual cycle of innovation positions Wittke™ as the forefront leader in side loader solutions across North America.

WEIGHT DISTRIBUTION

Over years of innovation, Wittke™ trucks prioritize ideal weight distribution. Our ongoing objective is to achieve the perfect material balance, ensuring units collect more waste while maintaining the highest legal payload.



ENVIROLINK™ HAS LAID THE FOUNDATIONS FOR A BRAND-NEW ERA IN TRUCK INTELLIGENCE.

An improved multiplex network and analog system, cameras and monitors, scales, diagnostic tools, safety interlocks, alerts, GPS tracking, and more are now packaged in a more precise, reliable, and efficient Smart Collection Package.



Up to 650 lbs/yd³ compaction

Packer shelf 24 inches wide

Body side mounted hydraulic valves (streetside)

12 yd³ hopper capacity

Single piece Abrasion Resistant steel body wall construction

Tailgates ranging from 2 yd³ to 4 yd³ based on body capacity

Starlight Body Sizes: 30 yd³ to 44 yd³ body sizes

Superduty Body Sizes: 34 yd³ to 44 yd³ body sizes

Curved body maximizes capacity, reducing weight

Zinc-plated hydraulic tubing

	AUTOMATED	MANUAL	RESIDENTIAL	COMMERCIAL	DEMOLITION	ORGANICS	ALLEYS TIGHT AREAS	RECYCLING	TIPTO DUMP	FULL EJECT	SPLIT BODY	50>82 DGE	50>96 DGE	50>100 DGE	60>97 DGE	FRAME	ROOF	CAB	TAILGATE	EV
WITTKE Wittke Front Loaders			●	●				●		●					◆ CNG	◆ CNG	◆ CNG		◆ CNG	●



STRONGEST ARMS

Wittke™ arms deliver swift and smooth lifting. Thanks to the high-flow Muncie pump, packing takes just 18-20 seconds, and an arm cycle, only 12-14 seconds.



ARM TRUNNION BEARINGS

Unlike standard bushing designs that require frequent replacement due to the daily cycling of front loader arms, Wittke's engineered steel trunnion bearings, mounted externally, are designed to last the unit's entire lifespan with proper lubrication.



SHELF DESIGN & CANOPY SWEEPER

Effectively reduce debris on routes. The second arm lift directs waste to the hopper, not the ground. Wittke™ loaders feature gutters for fluid control, minimizing spillage.



PLOW-SHAPED PACKER PANEL

The unique plow shape of Wittke's packer ensures debris remains inside the body, not trapped behind it. The angled design enhances force transfer, resulting in a notable increase in compaction efficiency and reduced cleaning expenses.



DURASCOPE PACKER CYLINDERS*

Packer cylinders endure harsh conditions and are exposed to debris. Our enhanced design, featuring nitrated rods, advanced seals, and shavers, prevents contamination. Opting for Durascope can also lower maintenance costs. (*optional)



ABRASION RESISTANT STEEL

High-quality, lightweight yet durable AR steel in the body, packer, hopper, and tailgate. It offers 5 times the abrasion resistance of mild steel. It offers the best strength-to-weight ratio, achieving higher payloads.

*Compaction ratios will vary based on commodity and environmental factors

Wittke Front Loaders Specifications

Body Specifications	Starlight	Superduty
Body Floor	0.157" AR450 175,000psi	3/16" AR450 175,000psi
Body Sides	1/8" AR450 175,000psi	0.157" AR450 175,000psi
Body Roof	1/8" AR450 175,000psi	0.157" AR450 175,000psi
Tailgate (Curved Face)	1/8" AR450 175,000psi	0.157" AR450 175,000psi

Cylinder Specifications	Starlight	Superduty
Packer Cylinders (30yd³ bodies)	3 stages 5-1/2" bore x 133-9/16" stroke	-
Packer Cylinders (34yd³ bodies)	3 stages 5-1/2" bore x 167-13/16" stroke	3 stages 5-1/2" bore x 167-13/16" stroke
Packer Cylinders (38yd³ bodies)	3 stages 5-1/2" bore x 181-1/2" stroke	3 stages 5-1/2" bore x 181-1/2" stroke
Arms Cylinders (8,000 lbs Lifting capacity)	4-1/2" bore x 2" rod x 45-3/8" stroke	4-1/2" bore x 2" rod x 45-3/8" stroke
Forks Cylinders	3-1/2" bore x 1-3/4" rod x 19" stroke	3-1/2" bore x 1-3/4" rod x 19" stroke
Tailgate Cylinders	2-1/2" bore x 1-3/4" rod x 39" stroke	2-1/2" bore x 1-3/4" rod x 39" stroke
Top Door Cylinder	2-1/2" bore x 1-1/2" rod x 92" stroke	2-1/2" bore x 1-1/2" rod x 92" stroke

Performance	Starlight	Superduty
Arms Up	12 - 14 sec @ 700 rpm	12 - 14 sec @ 700 rpm
Arms Down	10 - 12 sec @ 700 rpm	10 - 12 sec @ 700 rpm
Forks Up	3.5 - 4.5 sec @ 700 rpm	3.5 - 4.5 sec @ 700 rpm
Forks Down	3.5 - 4.5 sec @ 700 rpm	3.5 - 4.5 sec @ 700 rpm
Packer Extend	14 - 18 sec @ 1500 rpm	14 - 18 sec @ 1500 rpm
Packer Retract	5 - 6 sec @ 700 rpm	5 - 6 sec @ 700 rpm
Top Door complete cycle	13 - 17 sec @ 700 rpm	13 - 17 sec @ 700 rpm
Tailgate Open	21 sec @ 700 rpm	21 sec @ 700 rpm
Tailgate Close (with Safety Flow limiter)	26 sec @ 700 rpm	26 sec @ 700 rpm

Packer Specifications	Starlight	Superduty
Compaction ratio (lbs/yd³)	600	650
Packer Panel Lower Face Plate	3/16" AR450 175,000psi (1/4" on 34 yd³ bodies)	1/4" AR450 175,000psi (1/4" on 34 yd³ bodies)
Packer Panel Upper Face Plate	0.157" AR450 175,000psi	0.157" AR450 175,000psi
Bottom packer Wear Shoes	3/8" AR450 175,000psi (Chromium optional)	3/8" AR450 175,000psi (Chromium optional)

Hopper Specifications	Starlight	Superduty
Hopper Size (yd³)	12	12
Hopper Width	80"	80"
Hopper Floor	3/16" AR450 175,000psi	1/4" AR450 175,000psi
Hopper Sides	0.157" AR450 175,000psi	3/16" AR450 175,000psi

Fork Specifications	Starlight	Superduty
Forks Thickness	1" Domex 100 100,000psi	1-1/2" Domex 100 100,000psi

Arm Specifications	Starlight	Superduty
Arm Construction	10,000 lbs load rated arms	10,000 lbs load rated arms
Arm Thickness	4"	4"
Arm Side Plates	1/4" 1 Domex 1000 100,000psi	1/4" Domex 1000 100,000psi
Arm Lifting Capacity	8,000 lbs (10,000 lbs optional)	8,000 lbs (10,000 lbs optional)

Hydraulics Specifications	Starlight	Superduty
Pump Make & Model	Denison T6DC (gear)	Muncie Live Pak (gear)
Pump Capacity	66 gpm @ 1500 rpm	60 gpm @ 1500 rpm
Max. Operating Pressure	2,500 psi	2,750 psi
Oil Reservoir	74 gal	74 gal

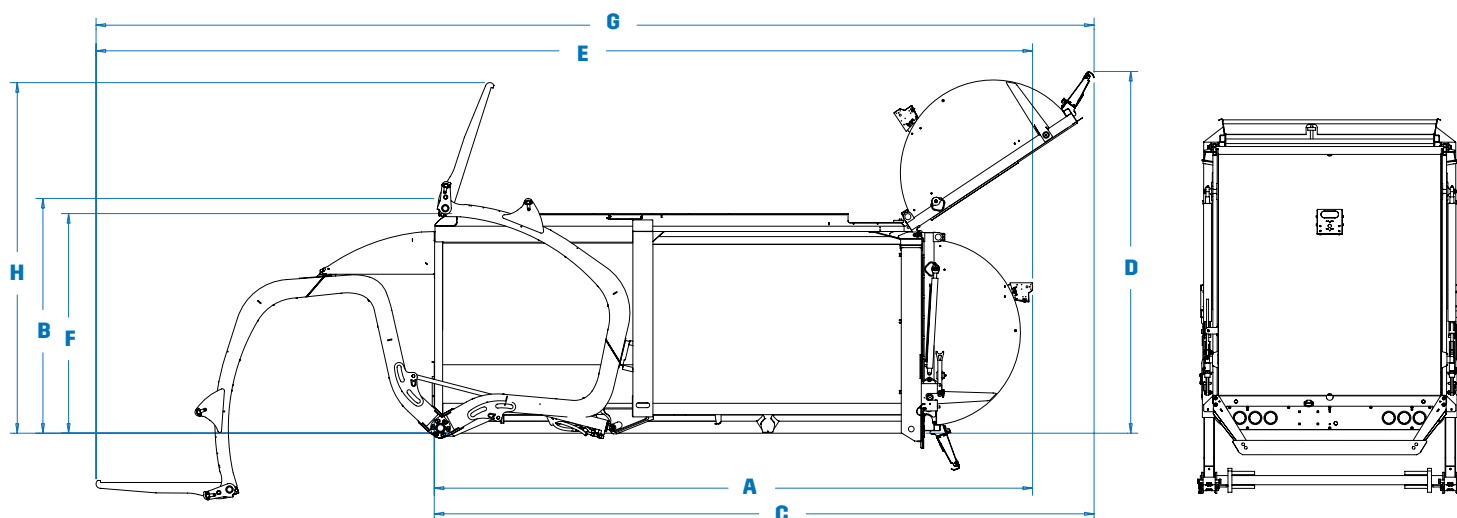

Body Dimensions	32yd³	34yd³	36yd³	36yd³	38yd³	40yd³	40yd³	42yd³	44yd³
	(30+2)	(30+4)	(30+6)	(34+2)	(34+4)	(34+6)	(38+2)	(38+4)	(38+6)
A. Overall Length with Arms Stowed. Tailgate Closed (in.)	245	260	275	269	284	299	296	311	326
Overall Width (in.)	102	102	102	102	102	102	102	102	102
B. Overall Height Above Frame with Arms Stowed. Tailgate Closed (in.)	118	118	118	118	118	118	118	118	118
C. Overall Length with Arms Stowed. Tailgate Open (in.)	305	305	305	329	329	329	356	356	356
D. Overall Height Above Frame with Arms Stowed. Tailgate Open (in.)	181	181	181	181	181	181	181	181	181
E. Overall Length With Arms/Forks Down. Tailgate Closed (in.)	414	429	444	438	453	468	465	480	495
F. Overall Height Above Frame With Arms/Forks Down. Tailgate Closed (in.)	110	110	110	110	110	110	110	110	110
G. Overall Length With Arms/Forks Down. Tailgate Open (in.)	474	474	474	498	498	498	525	525	525
H. Overall Height Above Frame with Arms Stowed/Forks Up. Tailgate Closed	175	175	175	175	175	175	175	175	175

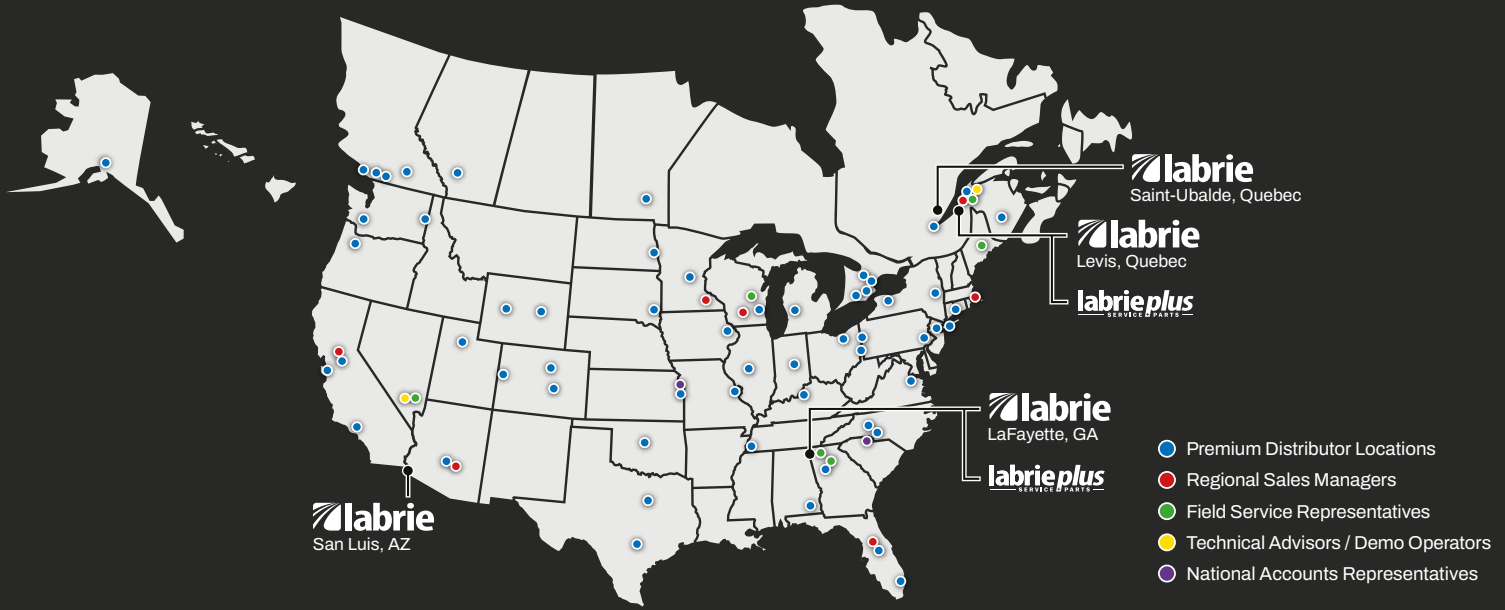

Our North American network is dedicated to quality.

Wittke™ trucks are supported by over 30 top-tier distributors spanning across 50+ sites in the US and Canada, guaranteeing a commitment to driving excellence and providing expert support.



Opt for the Wittke™ Pronto Stock Program when a pre-built model makes sense. Benefit from expedited delivery, cost savings, and a wide selection of models designed to cater to even the most demanding collection needs.



With Sourcewell, save time and money by combining the buying power of more than 50,000 government, education, and nonprofit organizations.



DRIVE EXCELLENCE™



175-B, route Marie-Victorin, Lévis, Quebec, Canada, G7A 2T3
 Toll Free: 1-800-463-6638 | Telephone: 418-831-8250
 sales@labriegrup.com | www.labriegrup.com

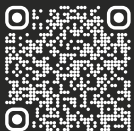

United States of America
 1198 Shattuck Industrial Blvd, Lafayette, GA, 30728
 Toll Free: 1-800-231-2771
 usa.labrieplus.com | partscenter@labrieplus.com

Canada
 175-A, route Marie-Victorin, Levis, Quebec, Canada, G7A 2T3
 Toll Free: 1-877-452-2743
 canada.labrieplus.com | labrieplusqc@labrieplus.com