



Minimax



Minimax Series

SOMETIMES IT PAYS TO HAVE A SMALL TRUCK

As the side-loader market leader, we designed the Minimax to uphold our reputation as an industry leader in quality, and innovative solutions. We've incorporated all the best features of our larger side loaders into the Minimax to ensure it is the most productive and reliable truck in its category. Its low loading height makes it ideal for fully automated, semi-automated, or manual collection, adapting to even the most complex applications.

The Minimax excels at missed pick-ups, parks and recreation areas, airports, university campuses, camping grounds, and all the other places where a smaller truck just makes more sense. Completely redesigned and built tougher, this truck is the ideal solution for optimized route efficiency and reduced costs.

Laying the foundations for a truly exceptional product.

LABRIE™ INNOVATIONS

With a strong emphasis on innovation, Labrie's engineering team has crafted a comprehensive range of customizable options to cater to even the most stringent customer requirements. We are poised and eager to embrace emerging industry trends and fulfill evolving customer demands. This perpetual cycle of innovation positions Labrie™ as the forefront leader in side loader solutions across North America.

WEIGHT DISTRIBUTION

Over years of innovation, Labrie™ trucks prioritize ideal weight distribution in all models. Our ongoing objective is to achieve the perfect material balance, ensuring models collect more waste while maintaining the highest legal payload.

Single piece body walls for increased strength and seamless appearance

AR Steel liners on the hopper floor and side walls

Optional Durascope nitrated packer & ejector cylinder with shaver

Crusher panel

Proportional joystick: Electric over hydraulic

Tailgates ranging from 0 yd³ to 4 yd³ based on body capacity

Tailgate auto-latch closes straight down to protect rubber seal

Up to 900 lbs/yd³ compaction

10 yd³ to 14 yd³ body sizes available

Helping Hand™

- 7 foot reach
- 400 lb lifting capacity

The hopper enclosed arm dumps directly into packer area

Easy, safe 1-man operation



ENVIROLINK™ HAS LAID THE FOUNDATIONS FOR A BRAND-NEW ERA IN TRUCK INTELLIGENCE.

An improved multiplex network and analog system, cameras and monitors, scales, diagnostic tools, safety interlocks, alerts, GPS tracking, and more are now packaged in a more precise, reliable, and efficient Smart Collection Package.

	AUTOMATED	MANUAL	RESIDENTIAL	COMMERCIAL	DEMOLITION	ORGANICS	ALLEYS TIGHT AREAS	RECYCLING	TIP TO DUMP	FULL EJECT	SPLIT BODY	50>82 DGE	50>96 DGE	50>100 DGE	60>97 DGE	FRAME	ROOF	CAB	TAILGATE	EV
Minimax Series	●	●	●				●	●	●			◇ CNG				◇ CNG	◇ CNG	◇ CNG		●



LOW PROFILE, SHORT WHEELBASE

The Minimax's short wheelbase makes it highly maneuverable, and with a GVWR under 33,000lbs, it is FET exempt.



STAND-UP DRIVE

Featuring multiple driving configurations for efficient one-man operation, the Minimax offers stand-up drive positions on either or both sides of the truck for added convenience.

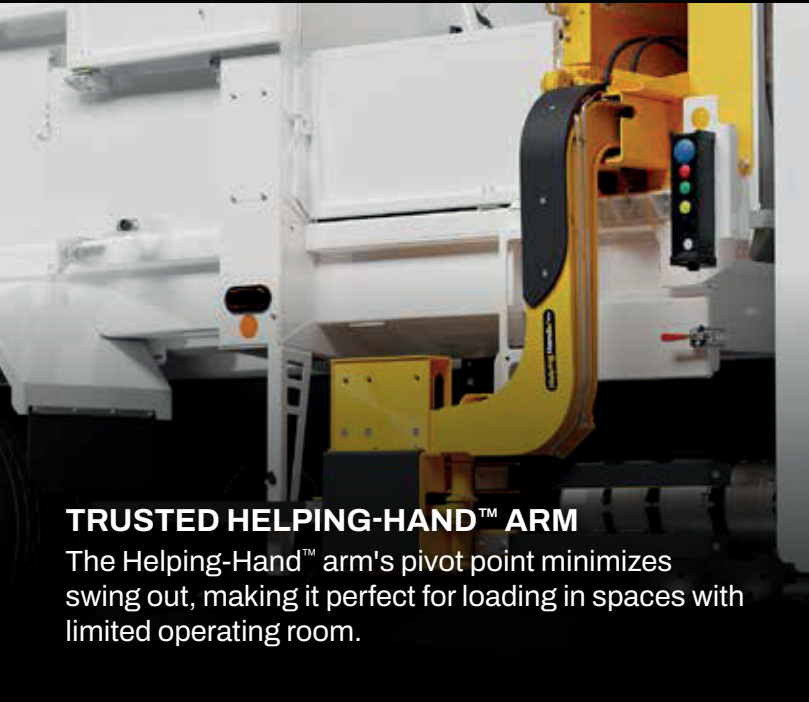

TRUSTED HELPING-HAND™ ARM

The Helping-Hand™ arm's pivot point minimizes swing out, making it perfect for loading in spaces with limited operating room.

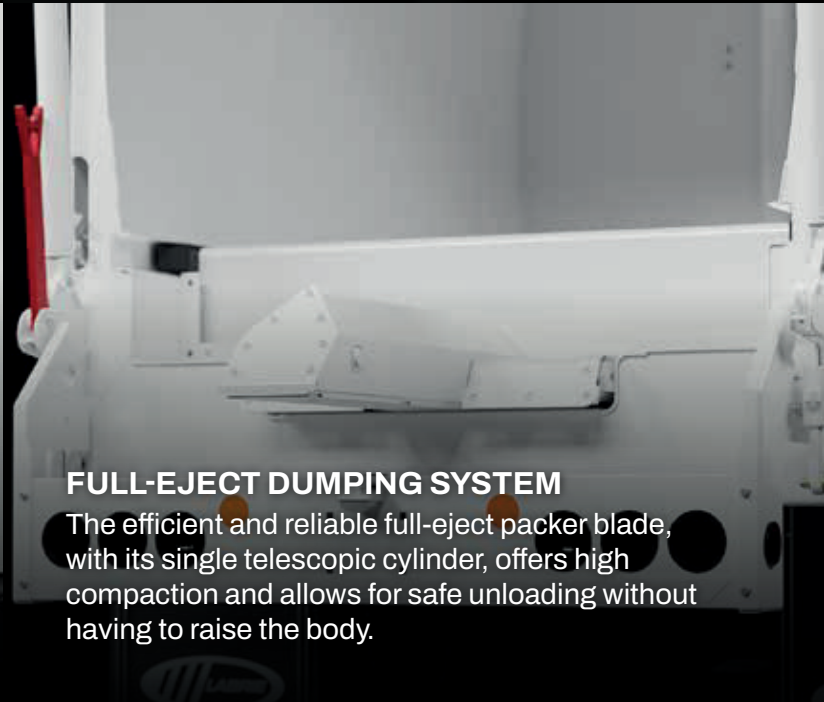

FULL-EJECT DUMPING SYSTEM

The efficient and reliable full-eject packer blade, with its single telescopic cylinder, offers high compaction and allows for safe unloading without having to raise the body.



LOADING HEIGHT

The low loading height makes it ideal for fully automated, semi-automated, or manual collection, adapting to even the most complex applications.

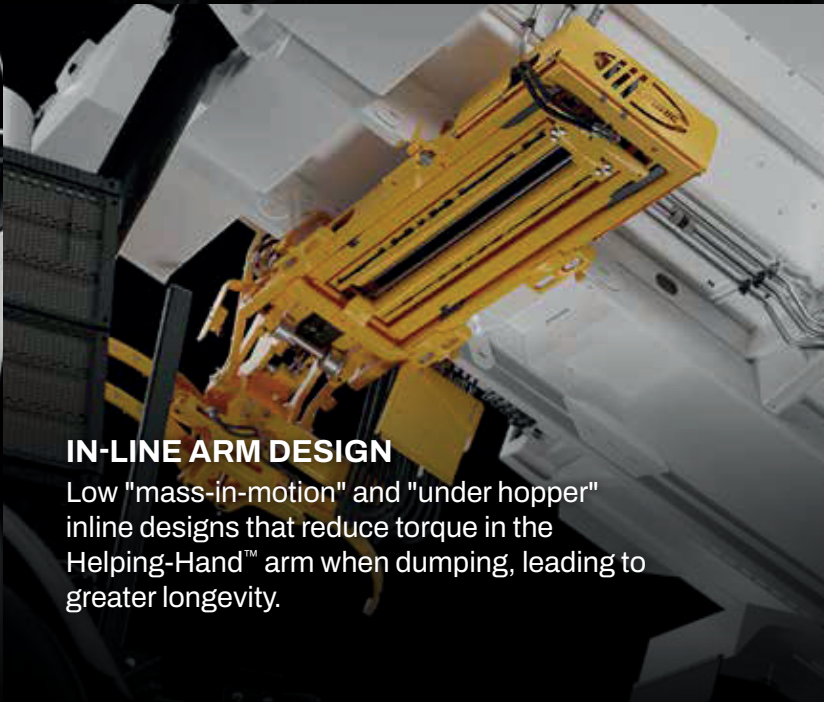

IN-LINE ARM DESIGN

Low "mass-in-motion" and "under hopper" inline designs that reduce torque in the Helping-Hand™ arm when dumping, leading to greater longevity.

Minimax Series Specifications

Body Specifications

Body Trough	1/4" AR450 175,000psi
Body Floor	1/4" 100QT 100,000psi
Body Sides (lower)	3/16" 100QT 100,000psi
Body Sides (upper)	12ga A1011 80,000psi
Body Roof	12ga A1011 80,000psi
Tailgate	12ga A715 80,000psi

Hydraulic Specifications

Pump Make & Model	Single Vane (Manual) / Dual Vane (Automated)
Pump Capacity (Manual)	20 gpm@1200 rpm
Pump Capacity (Automated)	BODY: 20 gpm@1200 rpm; ARM: 14 gpm@1200 rpm
Max. Operating Pressure	2,500 psi
Oil Reservoir	51 gal

Arm Specification (Automated Units)

Arm Lift Capacity	400 lbs
Arm Reach	84"
Swing out	27"
Arm Controls	Proportional joystick, electric over hydraulic

Cylinder Specifications

Packer Cylinder	3 stages 4-1/2" bore x 138" stroke
Tailgate Cylinders	2-1/2" bore x 1-3/4" rod x 31" stroke
Arm Extension Cylinder	2" bore x 1-1/4" rod x 70" stroke
Lifting Cylinder	3" bore x 1-1/2" rod x 16" stroke
Grabber Cylinder	1-1/2" bore x 1" rod x 6-1/4" stroke

Hopper Specifications

Hopper Size (yd ³)	1.5
Loading height	20.5" above frame
Hopper Trough	1/4" AR450 175,000psi
Hopper Floor	1/4" AR 450
Hopper Sides (lower)	3/16" 100QT 100,000psi

Packer Specifications

Compaction ratio (lbs/yd ³)	900
Packer Panel Face Plate	3/16" AR450 175,000psi
Packer Width	62-3/4"
Packer Height	17"
Packer Stroke	38"

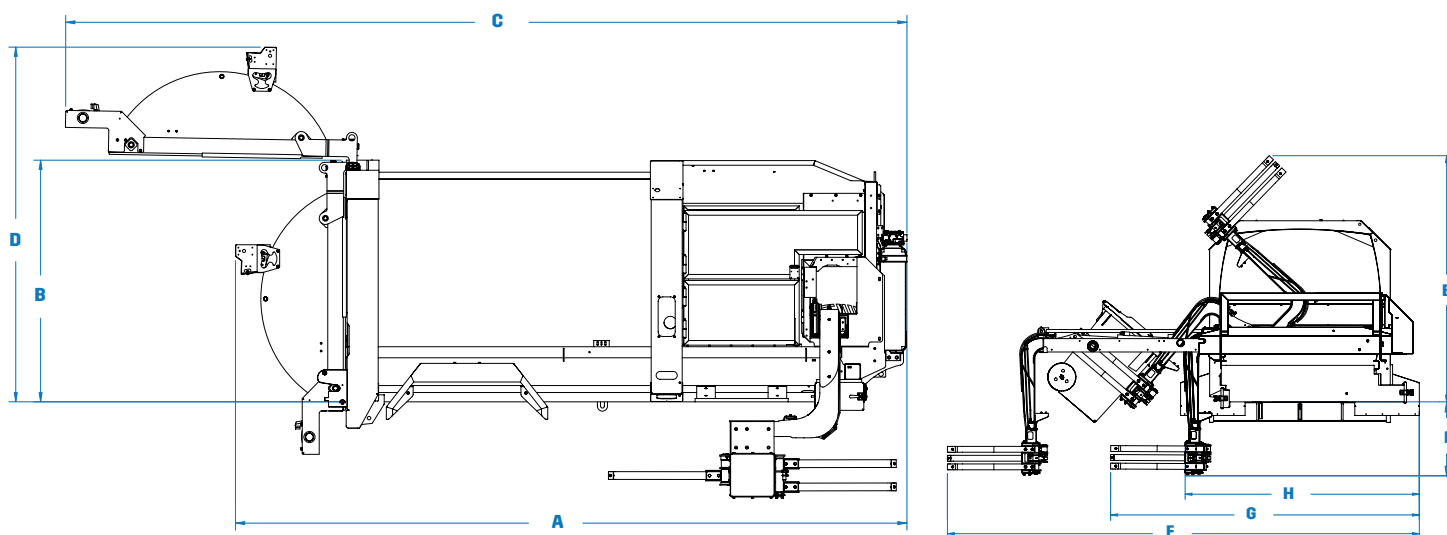

Body Dimensions

	10yd ³ (10+0)	12yd ³ (10+2)	14yd ³ (10+4)
A. Overall Length, Tailgate Closed (in.)	201	216	238
Overall Width (in.)	102	102	102
B. Overall Height Above Frame, Tailgate Closed (in.)	78	78	78
C. Overall Length, Tailgate Open (in.)	271	271	271
D. Overall Height Above Frame, Tailgate Open (in.)	99	114	136
E. Overall Height Above Frame When Dumping (in.)	105	105	105
F. Overall Width, Arm Out, Grabber Closed (in.)	202	202	202
G. Overall Width, Arm In, Grabber Closed (in.)	132	132	132
H. Overall Width, Arm In, Grabber Open (in.)	102	102	102
I. Distance between bottom of Grabber and chassis frame rail (in.)	25/31	25/31	25/31

Performance Specifications

Arm In	3.0 - 3.5 sec @ 1200 rpm	Packer complete cycle	12 sec
Arm Out	5.0 - 5.5 sec @ 1200 rpm	Tailgate Open	21 sec @ 700 rpm
Arm Up	3.0 - 3.5 sec @ 1200 rpm	Tailgate Close (with Safety Flow limiter)	26 sec @ 700 rpm
Arm Down	3.0 - 3.5 sec @ 1200 rpm	Crusher panel Up	4 sec @ 700 rpm
Grabber Open	1.3 - 1.8 sec @ 1200 rpm	Crusher panel Down	3 sec @ 700 rpm
Grabber Close	1.0 - 1.5 sec @ 1200 rpm		

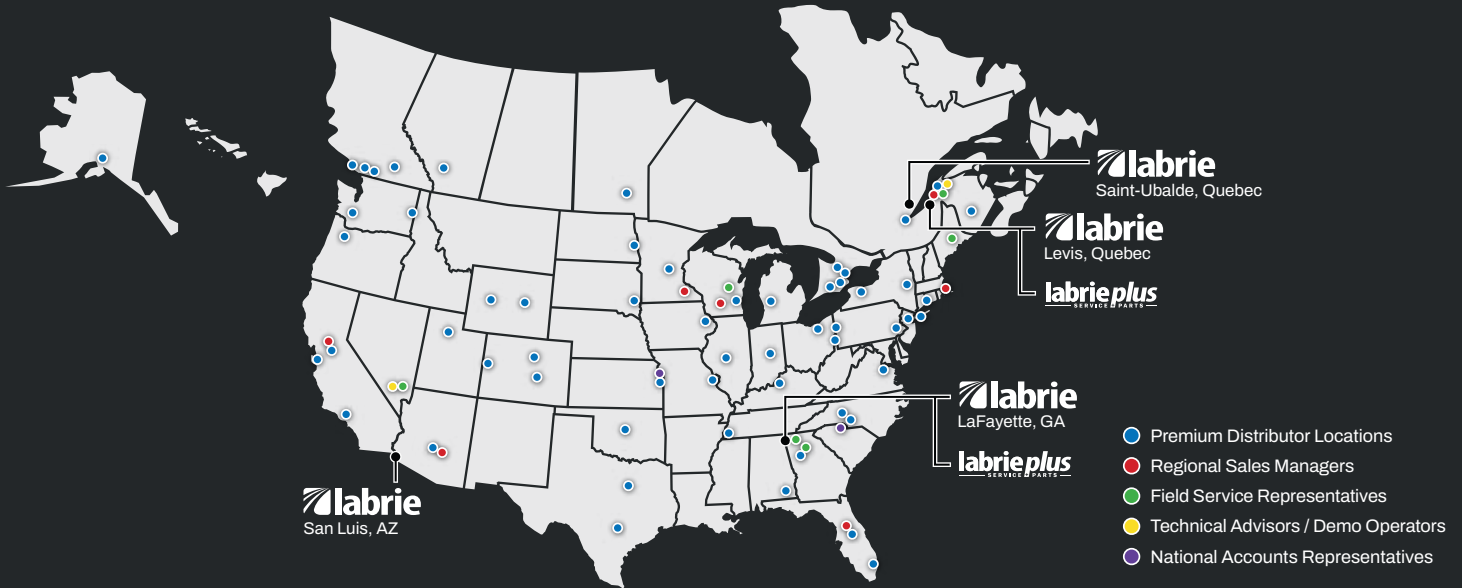

Our North American network is dedicated to quality.

Labrie™ trucks are supported by over 30 top-tier distributors spanning across 50+ sites in the US and Canada, guaranteeing a commitment to driving excellence and providing expert support.



Opt for the Labrie™ Pronto Stock Program when a pre-built model makes sense. Benefit from expedited delivery, cost savings, and a wide selection of models designed to cater to even the most demanding collection needs.



With Sourcewell, save time and money by combining the buying power of more than 50,000 government, education, and nonprofit organizations.



DRIVE EXCELLENCE™



175-B, route Marie-Victorin, Lévis, Quebec, Canada, G7A 2T3
 Toll Free: 1-800-463-6638 | Telephone: 418-831-8250
 sales@labriegrup.com | www.labriegrup.com



United States of America
 1198 Shattuck Industrial Blvd, Lafayette, GA, 30728
 Toll Free: 1-800-231-2771
 usa.labrieplus.com | partscenter@labrieplus.com

Canada
 175-A, route Marie-Victorin, Levis, Quebec, Canada, G7A 2T3
 Toll Free: 1-877-452-2743
 canada.labrieplus.com | labrieplusqc@labrieplus.com